

B-Questa®

BIK®
Best Sound System from Japan

OWNER'S MANUAL

使用说明书

BCQ-M65d

Speaker System

扬声器系统

BCQ-M65dB

Portable Speaker System

便携式扬声器系统

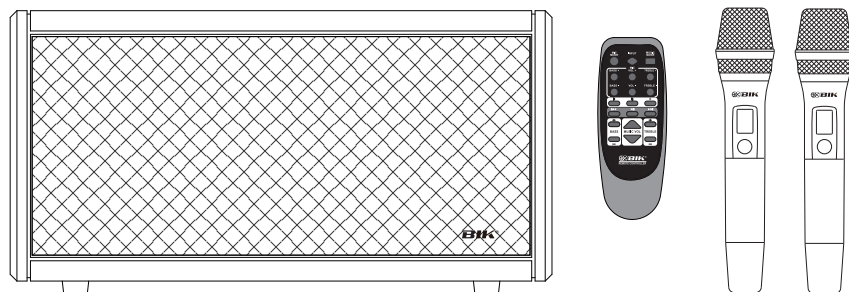

Thank you for purchasing our Speaker System(BCQ-M65d) or Portable Speaker System(BCQ-M65dB). Please read the owner's manual thoroughly prior to using the system in order for you to make it use with safety and at the best function.

Please keep the manual for future reference.



感谢您购买本公司的扬声器(BCQ-M65d)或便携式扬声器(BCQ-M65dB)。

为了尽快地熟悉掌握本产品的各项功能，使用前请先阅读本说明书。



阅读完后，请注意妥善保管。





CAUTION FOR SAFETY



This "Caution for safety" shows various kinds of pictures in order to be used safely and correctly and to prevent from damaging other people, and their property. Please read with full understanding, and carefulness.

 WARNING	This shows: Using this product with disregarding cautions might call for death or injury.
 CAUTION	This shows: Using this product with disregarding cautions might call for people to be harmed and goods to be damaged.

[Examples of pictures show]

-  △ Indicates cautions inclusive warnings.
-  ⊘ Indicators prohibition for action. Detail contents of prohibition are shown in the pictures (Pictures on left tells you not to re-assemble.)
-  ● Shows indication of full contents and action to be done. A concrete content (picture on left) tells :power supply plug to be taken out of outlet.

 WARNING	
<ul style="list-style-type: none"> ● Making use of this product under the circumstances that a smoke, an abnormal smell, an irregular sound come out, it may cause a fire and an electric shock. In this case, switch off the product, and take power supply plug out of the outlet right away. Bring it to the shop for repair. ● In case when water or foreign substances get into product, switch off right away, and take power supply plug out of outlet, and consult with the repair shop, other wise, it may cause a fire or an electric shock. ● In case when product is dropped, switch off right away, and take power supply plug out of outlet, and consult with the repair shop, otherwise, it may cause a fire or an electric shock. 	<p>WARNING</p>  <p>The power supply plug is pulled out from the outlet</p>
<ul style="list-style-type: none"> ● Re-assembling this product is highly prohibited, otherwise, it may cause a fire or an electric shock. ● Do not take amplifier out, otherwise, it may cause an electric shock. Inspection, repair should be done in the repair shop. 	 <p>Decomposition prohibition</p>
<ul style="list-style-type: none"> ● This product can no way be used in the bathroom, otherwise, it may cause a fire, or an electric shock. ● Pay attention not for water to go into or get wet. Or it may cause a fire or an electric shock. 	 <p>Use prohibition in water scene</p>
<ul style="list-style-type: none"> ● Do not use this product with a voltage other than indicated, or it may cause a fire, or an electric shock. ● This BCQ-M65d can be only used with AC power supply, which 110 - 260V 50/60Hz. ● This BCQ-M65dB can be only used with AC power supply, which 110 - 240V 50/60Hz. ● This product is not designed for built-in installation : do not place the product in an enclosed place such as a bookcase or rack. ● Be careful for power supply plug, or outlet not to get dust or to get it wet, or it may cause a fire. ● Do not put metal or flammable substances into this product, or it may cause a fire or an electric shock. ● Do not put any containers with water, or small metal substances near or on this product, or it may cause a fire, or an electric shock, and it becomes out of order. 	 <p>PROHIBITION</p>

 CAUTION	
<ul style="list-style-type: none"> ● When this product is not used for a longer period, power supply plug should be taken out of outlet. ● In case the thunder is generated near-by, take power supply plug out of outlet right away, or it may cause a fire or an electric shock. ● If this product needs to be moved, switch off first, and then take power supply plug out, or it may damage cord, and may cause a fire or an electric shock. 	 <p>The power supply plug is pulled out from the outlet</p>
<ul style="list-style-type: none"> ● Do not put this product near cooking counter or damp supply outlet, or it may cause a fire or an electric shock. ● Do not put this product on unstable desk, it may cause damage or injury when dropped. ● Do not allow to come to heating equipment, or it may melt code surface and cause a fire or an electric shock. ● Do not leave this product for a longer period such as in the cars where all windows are shut, or place where direct sunshine hits. Or it may damage each part of this product, and may cause a fire. ● Do not plug in or plug out with wet hands, or it may cause an electric shock. ● When taking power supply plug out, do not pull out cord, or it may damage cord, and cause a fire or an electric shock. Grip plug itself when taking out of outlet. ● If the built-in battery is fully charged and the battery life is significantly reduced, it is time to replace the battery. Contact the repair shop before replacing the battery. 	 <p>CAUTION</p>

FUNCTION AND NAME

Amplifier operational panel (BCQ-M65d and BCQ-M65dB)

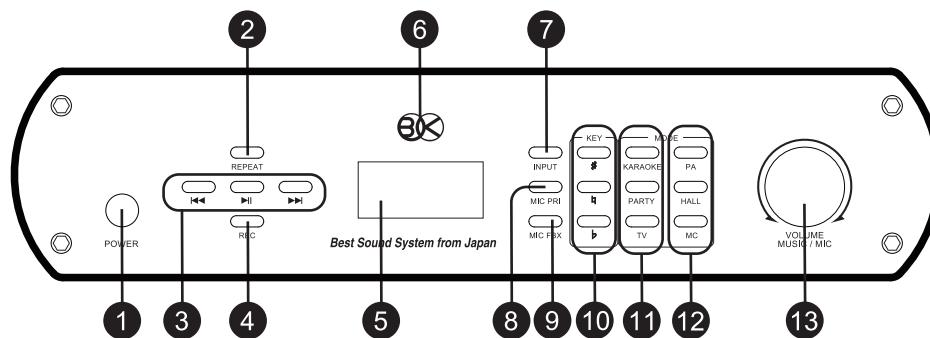

- 1 POWER SWITCH**
Long press to power on, and Long press to power off.
- 2 REPEAT BUTTON**
To switch the repeat of one or all songs.
- 3 REVERSE, PLAY / PAUSE / FORWARD BUTTON**
◀◀ : Reverse ▶▶ : Play, Pause ▶▶▶ : Forward
Rewind by pressing and holding the ◀◀ button.
Fast forward by pressing and holding the ▶▶▶ button.
- 4 REC BUTTON**
To record of MIC and music to USB memory.
- 5 DISPLAY**
To show the operate mode.
- 6 POWER INDICATOR**
Glows when power is turned on.
- 7 INPUT BUTTON**
To select the input in the order of BLUE, OPT, USB, ARC.
LINE input is selected when plugged in.
- 8 MIC PRIORITY**
To reduce other music, when MIC voice is input.
- 9 MIC FBX**
To adjust Feed Back Celler of MIC.
- 10 KEY CONTROL BUTTON**
To adjust key control of Music.
- 11 MUSIC MODE BUTTON**
Three music modes can be selected.
- 12 MIC MODE BUTTON**
Three MIC modes can be selected.
- 13 MASTER VOLUME**
To adjust Music and MIC volume. (From “00” to “32”)
Press the knob to switch between Music and MIC.

Amplifier Rear panel (BCQ-M65d)

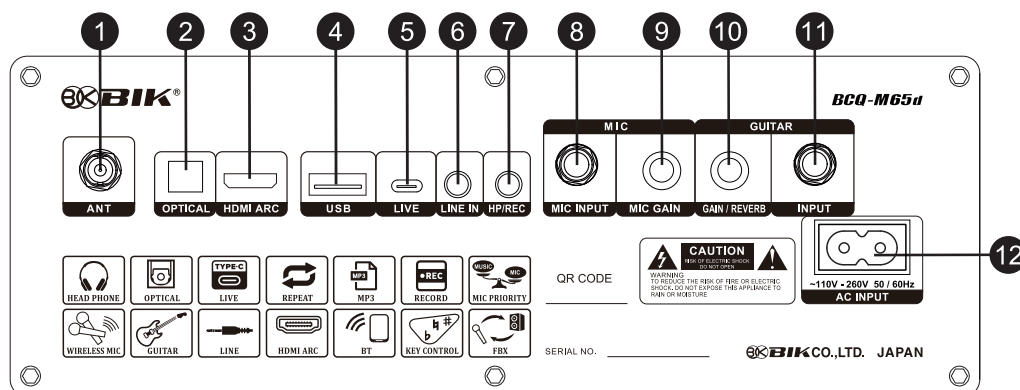

- 1 Wireless MIC ANTENNA**
Adding an antenna increases sensitivity.
- 2 OPTICAL INPUT**
Connect the optical input.
- 3 HDMI ARC PORT**
Connect the HDMI ARC.
- 4 USB PORT**
Connect the USB memory.
Playback of music on USB memory and recording to USB memory.
- 5 LIVE PORT**
Connect the smartphone with USB type C cable.
※Use a USB Type C OTG compatible cable.
- 6 LINE INPUT (3.5mm)**
Connect the line input.
- 7 HP / REC OUTPUT**
Connect the headphone or recorder.
- 8 MIC INPUT**
Connect the wired MIC.
- 9 MIC GAIN VOLUME**
To adjust the input gain for wired MIC.
- 10 GUITAR GAIN AND REVERB VOLUME**
To adjust the input gain for instrument.
Press the volume to switch between GAIN and REVERB.
- 11 GUITAR INPUT**
Connect the instrument.
- 12 AC INPUT**
Power input AC110 - 260V 50Hz / 60Hz.

Amplifier Rear panel (BCQ-M65dB)

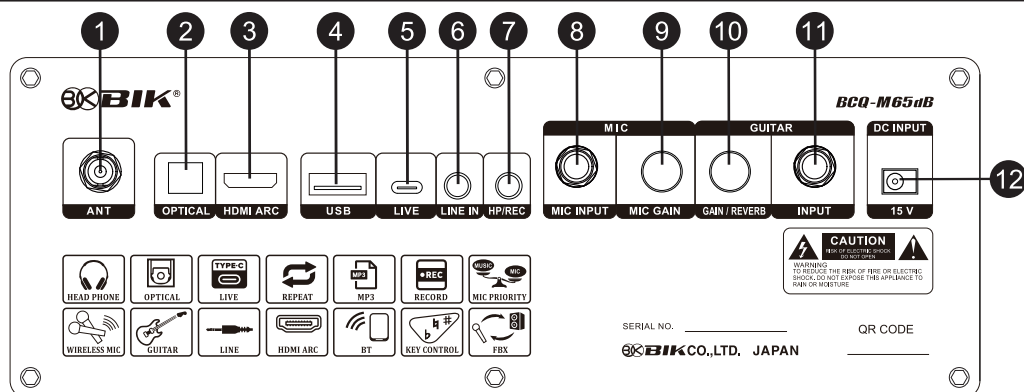

1 Wireless MIC ANTENNA

Adding an antenna increases sensitivity.

2 OPTICAL INPUT

Connect the optical input.

3 HDMI ARC PORT

Connect the HDMI ARC.

4 USB PORT

Connect the USB memory.
Playback of music on USB memory and recording to USB memory.

5 LIVE PORT

Connect the smartphone with USB type C cable.
※Use a USB Type C OTG compatible cable.

6 LINE INPUT (3.5mm)

Connect the line input.

7 HP / REC OUTPUT

Connect the headphone or recorder.

8 MIC INPUT

Connect the wired MIC.

9 MIC GAIN VOLUME

To adjust the input gain for wired MIC.

10 GUITAR GAIN AND REVERB VOLUME

To adjust the input gain for instrument.

Press the volume to switch between GAIN and REVERB.

11 GUITAR INPUT

Connect the instrument.

12 DC INPUT

Connect the included AC adapter (DC 15V).

REMOTE CONTROLLER

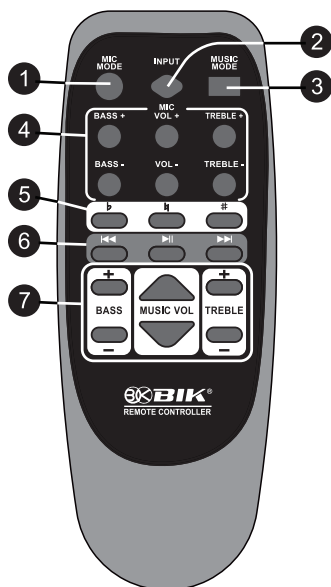

1 MIC MODE BUTTON

Three MIC modes can be selected.

2 INPUT BUTTON

To select the input in the order of BLUE, OPT, USB and ARC. LINE input is selected when plugged in.

3 MUSIC MODE BUTTON

Three music modes can be selected.

4 MIC TONE AND VOLUME BUTTON

To adjust the MIC BASS, TREBLE and volume.

5 KEY CONTROL BUTTON

To adjust key control of Music.

6 REVERSE, PLAY / PAUSE / FORWARD BUTTON

◀◀ : Reverse ▶▶ : Play, Pause ▶▶▶ : Forward
Rewind by pressing and holding the ◀◀ button.
Fast forward by pressing and holding the ▶▶▶ button.

7 MUSIC TONE AND VOLUME BUTTON

To adjust the music BASS, TREBLE and volume.

WIRELESS MICROPHONE

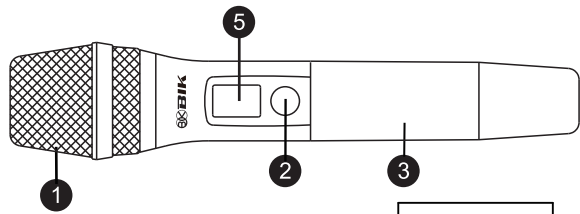

- ① Microphone head case
- ② Power Switch
- ③ Grip
- ④ Battery case for Lithium ion battery (18650).
- ⑤ Display
- ⑥ CH SWITCH

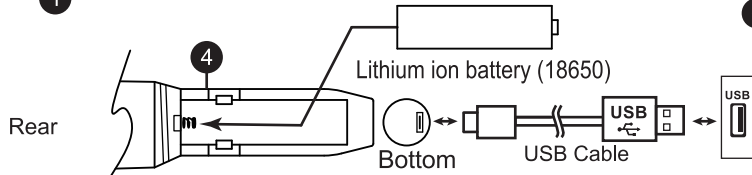

Figure with the grip ③ removed.

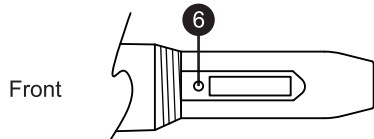
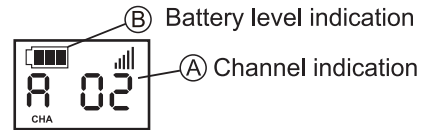
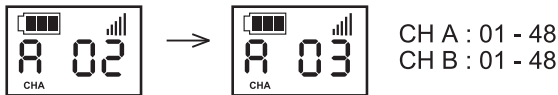

Figure with the grip ③ removed.



● How to set Channel (Frequency)

1. Changing by pressing a switch ⑥.



- ※ Press and hold (about 5 sec) the power button when the power is off to switch between CH A and CH B.

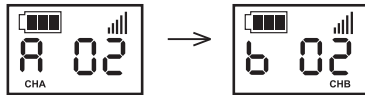

● How to lock

1. Hold down (about 5 sec) the power button ② and the channel button ⑥ simultaneously.

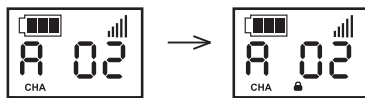

- ※ The channel is set to "01" and can be reset with the same operation.

CONNECTION

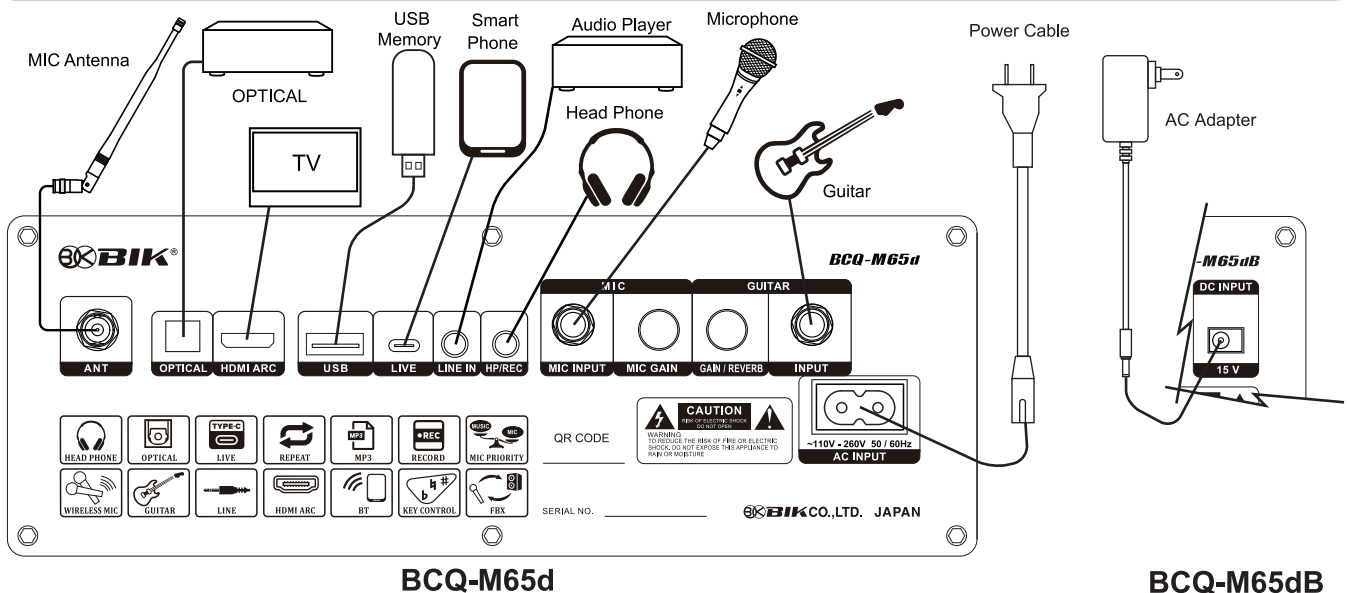

- ※ Connect the LIVE terminal (USB Type C) and your smartphone using an OTG cable. Set the input and output of your smartphone to external device.

- ※ Please fully charge the battery before using this product for the first time. (Only BCQ-M65dB)

ANY TROUBLES?

Any troubles? Please check the followings. Your careless mistakes seem to be troubles.
Consult with your dealers in case any troubles can not be solved after checking the followings.

Trouble	Cause	Remedy
Not turned on	<ul style="list-style-type: none"> ● Not plugged in (BCQ-M65d) ● Battery voltage drop (BCQ-M65dB) 	<ul style="list-style-type: none"> ● Plug cord in ● Charge Battery
No sound produced even music starts in "On position"	<ul style="list-style-type: none"> ● Volume is set at minimum position ● Input signal wires in poor or not connected correctly 	<ul style="list-style-type: none"> ● Set volume at your requited position ● Re-connect once again
Noisy	<ul style="list-style-type: none"> ● Battery voltage drop (BCQ-M65dB) 	<ul style="list-style-type: none"> ● Plug in the power cable

SPECIFICATIONS (BCQ-M65d)

Amplifier

Maximum Output Power	88W / 4Ω
Frequency Response	20Hz - 20kHz
LINE INPUT	710mV
MIC INPUT	20mV
GUITAR INPUT	710mV
HP/REC OUTPUT	2.3V

Speaker

Woofers	160mm Cone Type X 2pcs
Tweeters	77mm Cone Type X 2pcs

Wireless Microphone

Voltage	DC3. 7V - 4. 2V (Lithium ion battery 1 piece)
Operating current	80mA (MIN)
Frequency	UHF Frequency conversion / 640 - 689MHz
Channel	MIC A : 640 - 664MHz (A01 - A48) MIC B : 665 - 689MHz (B01 - B48)
Dynamic range	105 dB (MIN)
Frequency response	40Hz - 15kHz
Microphone Type	Dynamic Type / Unidirectional

Power Supply, Others

Power Voltage	AC110 - 260V 50/60Hz
Power Consumption	37.8 W
Dimensions (W x H x D)	481 x 240 x 233 mm
Weight	8.9 Kg

Accessories

Owner's manual	1
Power Cable	1
Remote Controller	1
Wireless Microphone	(MIC A, MIC B) 2
USB Cable	1

- Design and specifications subject to change without notice.

SPECIFICATIONS (BCQ-M65dB)

Amplifier

Maximum Output Power	88W / 4Ω
Frequency Response	20Hz - 20kHz
LINE INPUT	710mV
MIC INPUT	20mV
GUITAR INPUT	710mV
HP/REC OUTPUT	2.3V

Speaker

Woofers	160mm Cone Type X 2pcs
Tweeters	77mm Cone Type X 2pcs

Wireless Microphone

Voltage	DC3. 7V - 4. 2V (Lithium ion battery 1 piece)
Operating current	80mA (MIN)
Frequency	UHF Frequency conversion / 640 - 689MHz
Channel	MIC A : 640 - 664MHz (A01 - A48) MIC B : 665 - 689MHz (B01 - B48)
Dynamic range	105 dB (MIN)
Frequency response	40Hz - 15kHz
Microphone Type	Dynamic Type / Unidirectional

Power Supply, Others

Battery	8000 mAh
Power Voltage	AC110 - 240V 50/60Hz
Power Consumption	37.8 W
Dimensions (W x H x D)	481 x 240 x 233 mm
Weight	9.7 Kg

Accessories



Owner's manual	1
AC Adapter	1
Remote Controller	1
Wireless Microphone	(MIC A, MIC B) 2
USB Cable	1

- Design and specifications subject to change without notice.



目录	安全注意事项	7	连接方法	10	产品规格	11
	各部分的功能及名称	8	故障分析处理	11		





安全注意事项



安全注意事项是为了安全正确使用本商品，防止给自己及他人带来财产损害。以下用图标形式加以注明。请仔细阅读本文。

	警告	无视或误用会有造成人身事故的可能性。
	注意	无视或误用会有造成人身伤残，财产损坏的可能性。

[图标表示的说明]

-  △记号是表示注意（包括警告）的内容。
-  ⊘记号是表示禁止内容。
具体的禁止内容注明在图标中（例：左图是表示禁止分解）。
-  ●记号是表示强制行为。
具体的指示内容注明在图标中（例：左图是表示拔下电源插头）。

 警告	
<ul style="list-style-type: none"> ● 在使用时，如果有冒烟、异味、异音等异常现象发生，为避免发生火灾，触电现象等，请立即切断本机电源，然后拔下电源插头。确认没有再冒烟后，到贩卖店进行修理。 ● 在使用时如有水或异物等混入机体内，首先切断机体电源，然后拔下电源插头。请尽快与贩卖店联系进行修理。在未进行维修的状态下使用，会引起火灾，触电等问题。 ● 在使用时如不慎掉落在地上造成损坏时，首先切断机体电源，然后拔下电源插头。请尽快与贩卖店联系进行修理。在未进行维修的状态下使用，会引起火灾，触电等事故。 	<p>警告</p>  从插座上拔下电源插头
<ul style="list-style-type: none"> ● 请勿分解、改装本机器。会引起火灾、触电、故障等事故。 ● 绝对禁止私自拆解功率放大器，以免造成触电等事故。检测、修理等请交由贩卖店进行处理。 	 分解 禁止
<ul style="list-style-type: none"> ● 请防止机器进水或使机器受潮，会引起火灾、触电等事故。 	 潮湿场所 禁止使用
<ul style="list-style-type: none"> ● 请勿使用指定以外的电源电压。会引起火灾，触电等事故。 ● 本机器的(BCQ-M65d)电源电压使用范围AC110V - 260V 50/60Hz。 ● 本机器的(BCQ-M65dB)电源电压使用范围AC110V - 240V 50/60Hz。 ● 本产品的的设计是采用风扇强制排风散热，请勿将机器放置于密闭环境或不通风的地方。 ● 请不要用带有灰尘，潮湿的插头和插座，会引起火灾等事故。 ● 请注意不要将金属物品、或易燃物品插入机器中，以免引起火灾、触电等事故。 ● 请不要在机器上或附近放置装有液体的容器及金属物。 	 禁止

 注意	
<ul style="list-style-type: none"> ● 旅行等长时间不使用时，为了安全请务必拔下电源插头。 ● 如近距离内有雷电现象时，请拔下电源插头，由于雷电原因，会引起火灾、触电、故障等事故。 ● 移动时，首先切断电源，然后务必拔下电源插头，再拆下其他接线。如电源线有损坏，会引起火灾、触电等事故。 	 从插座上拔下电源插头
<ul style="list-style-type: none"> ● 请勿放置在灶台、加湿器及有油烟、雾气的地方。会引起火灾、触电等事故。 ● 请勿放置在不安稳的桌上、或倾斜的地方。会容易掉落、翻倒而造成损坏、损伤。 ● 请避免将电源线靠近过热的物品，以免电源线被熔化，而引起火灾、触电等事故。 ● 请勿放置在紧闭车窗的汽车内、或阳光直射及高温的地方。以免造成零部件的损坏，而引起火灾。 ● 请勿放置在潮湿、多灰尘的地方。以免引起火灾、触电等事故。 ● 请不要用潮湿的手拔、插电源插头。以免引起触电事故。 为了防止因电源线的损坏而引起火灾、触电等事故。在拔电源插头时，请务必握住电源插头后再拔下。 ● 如果内置电池的续航时间明显缩短的话，说明快到电池的使用寿命，应联系贩卖店更换电池。 	 注意

各部分的功能及名称

功放操作面板(BCQ-M65d 和 BCQ-M65dB共通)

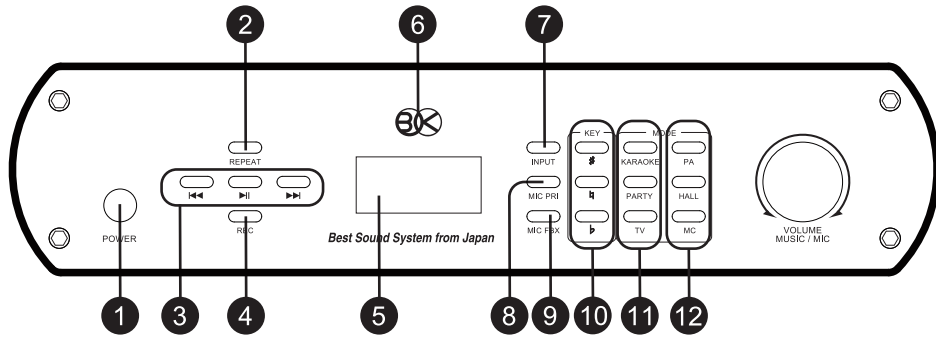

- ① 电源开关
长按开机/关机。
- ② 循环按键
“ONE”表示单曲循环。“ALL”表示顺序循环。
- ③ 上一曲, 播放/暂停, 下一曲
◀◀: 上一曲 ▶▶: 下一曲
|◀▶: 播放/暂停
按住 ◀◀ 快退
按住 ▶▶ 快进
- ④ 录音按键
收录麦克风和音乐的声音, 保存到U盘
- ⑤ 显示屏
显示实时操作状态
- ⑥ 电源指示灯
电源打开时亮起。
- ⑦ 输入切换按键
切换输入信号(蓝牙, 音频信号, U盘, 数字光纤)
当音频信号连接后可以被选择
- ⑧ 麦克风优先按键
使用麦克风时背景音量变小。
- ⑨ 啸叫抑制按键
- ⑩ 升降调按钮
b: 降调、#: 升调、q: 复原
- ⑪ 音乐效果按键
三种音乐效果模式可以选择
- ⑫ 麦克风效果按键
三种麦克风效果模式可以选择
- ⑬ 音量调节旋钮
调节音乐和麦克风的音量大小(从0到32)
按下旋钮可在音乐音量和麦克风音量之间切换。

功放后面板(BCQ-M65d)

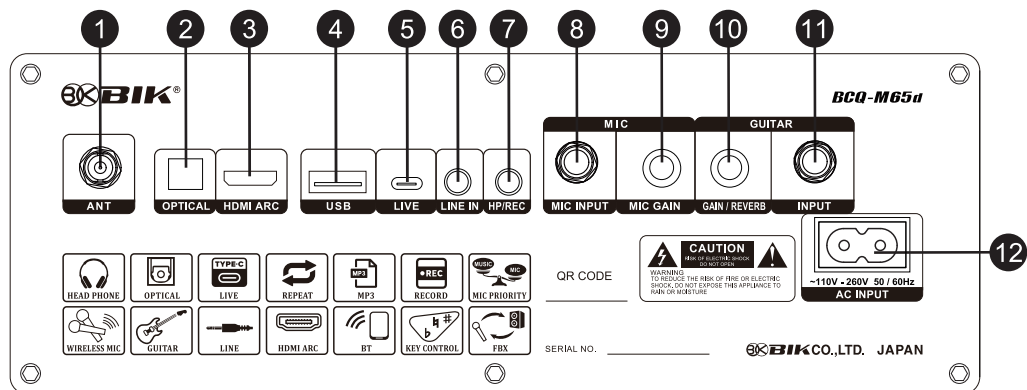

- ① 麦克风天线端子
连接附属天线可提高信号强度
- ② 数字光纤信号输入端子
- ③ HDMI ARC输出端子
- ④ USB端子
插入U盘
可以播放U盘中的歌曲和录音
- ⑤ 直播端子
使用Type C数据线连接智能手机
※使用兼容OTG的USB Type C数据线。
- ⑥ 音频信号输入端子(3.5mm)
- ⑦ 耳机/录音输出端子
- ⑧ 麦克风输入接口
- ⑨ 麦克风输入音量旋钮
- ⑩ 吉他输入音量和混响音量旋钮
调整乐器的输入音量
按下按键可在GAIN和REVERB之间切换。
- ⑪ 吉他接口
- ⑫ AC电源输入接口(AC110-260V 50/60Hz)

功放后面板(BCQ-M65dB)

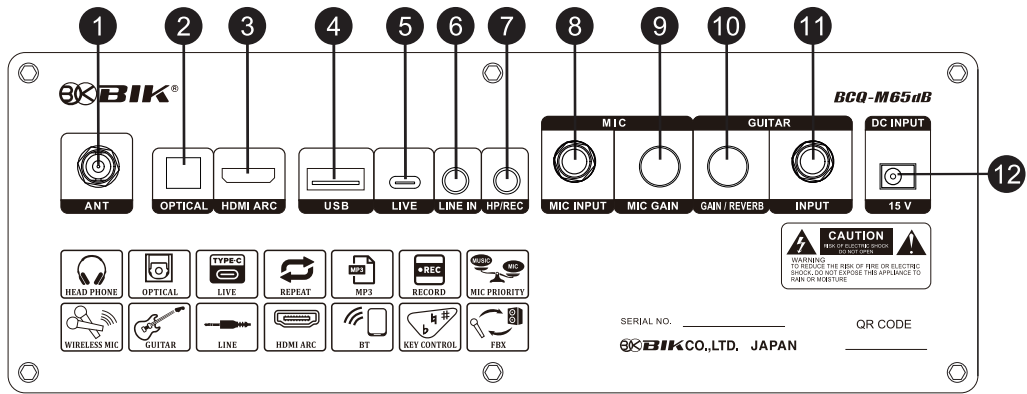

- ① 麦克风天线端子
连接附属天线可提高信号强度
- ② 数字光纤信号输入端子
- ③ HDMI ARC 输出端子
- ④ USB端子
插入U盘
可以播放U盘中的歌曲和录音
- ⑤ 直播端子
使用Type C数据线连接智能手机
※使用兼容OTG的USB Type C数据线。
- ⑥ 音频信号输入端子(3.5mm)
- ⑦ 耳机 / 录音输出端子
- ⑧ 麦克风输入接口
- ⑨ 麦克风输入音量旋钮
- ⑩ 吉他输入音量和混响音量旋钮
调整乐器的输入音量
按下按键可在 GAIN 和 REVERB 之间切换。
- ⑪ 吉他接口
- ⑫ DC电源输入接口
连接附属的电源适配器 (DC 15V)

遥控器

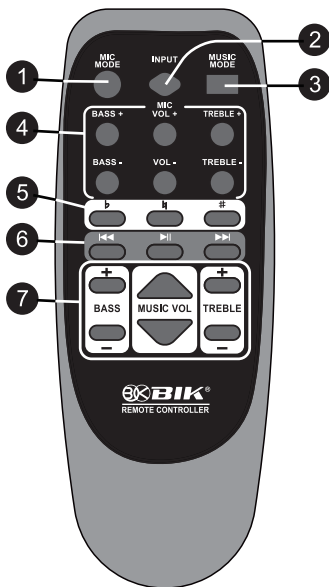

- ① 麦克风效果按键
三种麦克风效果模式可以选择
- ② 输入切换按键
切换输入信号(蓝牙, 音频信号, U盘, 数字光纤)
当音频信号连接后可以被选择
- ③ 音乐效果按键
三种音乐效果模式可以选择
- ④ 麦克风音调和音量按键
调节麦克风的低音、高音和音量。
- ⑤ 升降调按钮
♭: 降调、#: 升调、♮: 复原
- ⑥ 上一曲, 播放 / 暂停, 下一曲
◀◀: 上一曲 ▶▶: 播放/暂停 ▶▶: 下一曲
按住 ◀◀ 快退
按住 ▶▶ 快进
- ⑦ 音乐音调和音量按键
调节音乐的低音、高音和音量。

无线麦克风

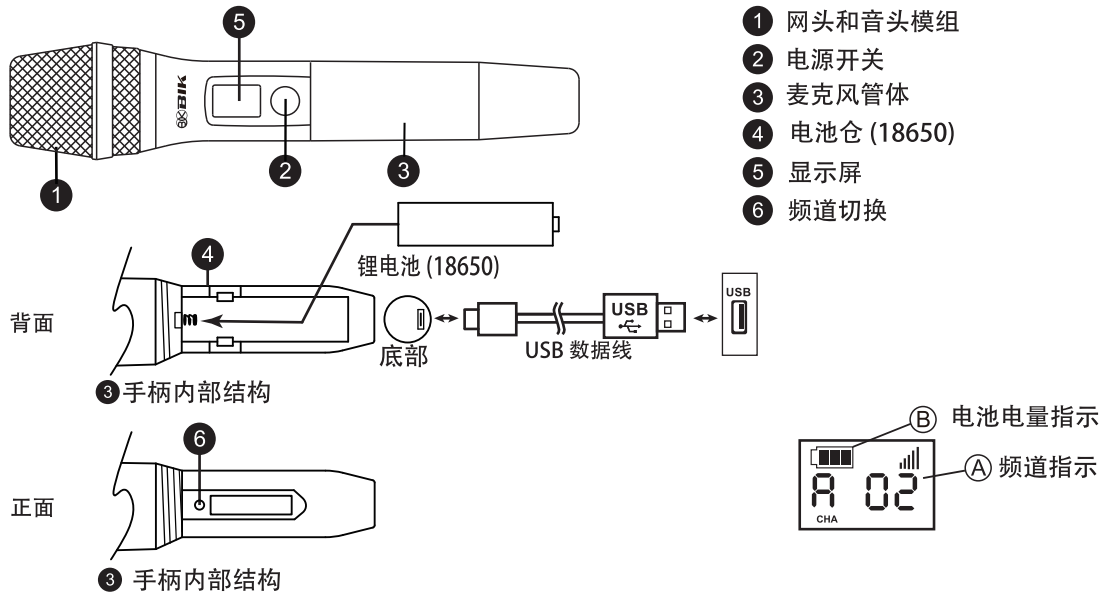

● 如何设置频道 (频率)

1. 通过按下频道切换按键 ⑥ 进行更改

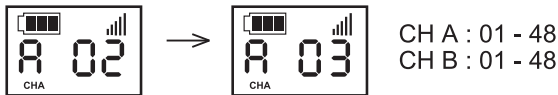

※ 关机状态下长按电源开关 (约5秒) 可在CH A和CH B之间切换。

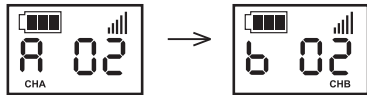

● 如何设置锁定

1. 同时按住 (约5秒) 电源开关 ② 和频道切换按键 ⑥

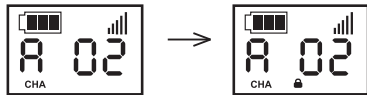

※ 将频道设置为“01”，可通过相同操作重置。

连接方法

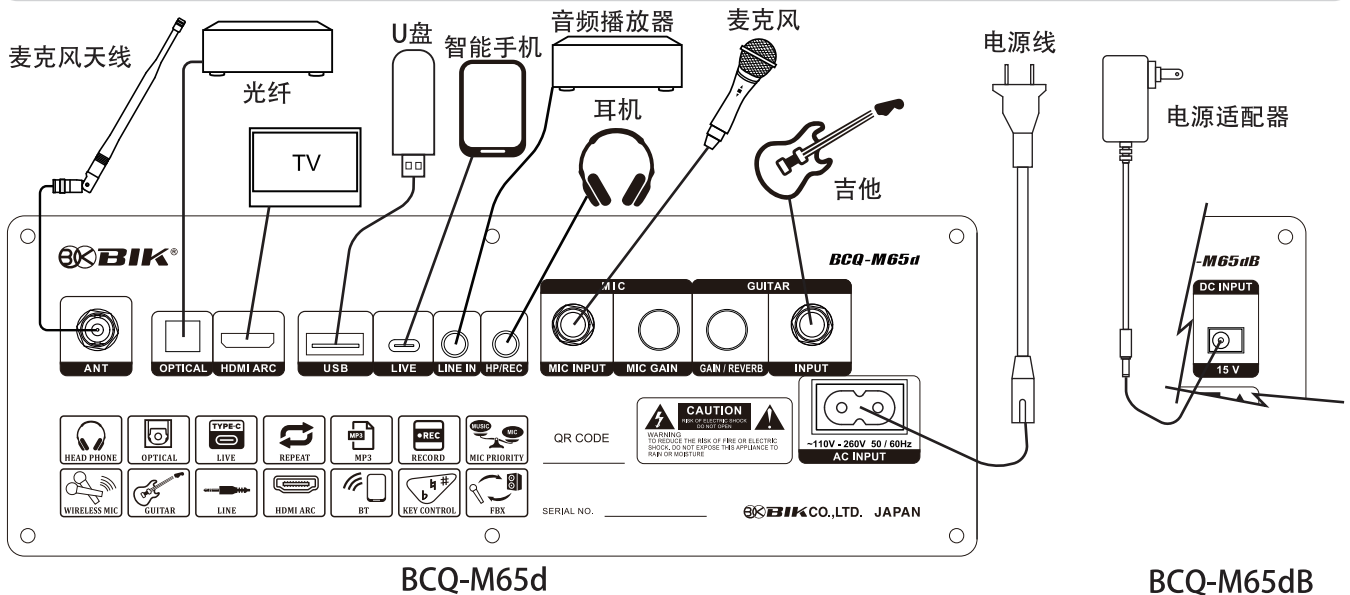

※ 使用 OTG 数据线连接直播端子 (USB Type C) 和您的智能手机。需要将智能手机的输入和输出设置为外部设备。

※ 首次使用本产品前，请先将电池充满电。(仅限BCQ-M65dB)

故障分析处理

如发现有故障请根据以下方法检查。偶尔会有因为操作错误而误认为是故障的现象。根据以下方法检查也不能解决的情况下，请直接联系贩卖店。

症状	原因	处理
不通电	<ul style="list-style-type: none"> ● 没有插入电源(BCQ-M65d) ● 电池电量不足(BCQ-M65dB) 	<ul style="list-style-type: none"> ● 插入电源线 ● 充电
通电后有音乐信号输入但是没有声音	<ul style="list-style-type: none"> ● 音量旋钮没有打开 ● 输入信号连接线不良或者没有连接好 	<ul style="list-style-type: none"> ● 调节适当的音量位置 ● 检查连接线，重新连接
出现杂音	<ul style="list-style-type: none"> ● 电池电量过低(BCQ-M65dB) 	<ul style="list-style-type: none"> ● 插入电源线/充电

产品规格(BCQ-M65d)

功能放大器部分

最大输出	88W / 4Ω
频率特性	20Hz - 20kHz
音乐输入灵敏度	710mV
麦克风输入灵敏度	20mV
吉他输入灵敏度	710mV
耳机 / 录音输出端子	2.3V

扬声器部分

低音单元	160mm圆锥形(2个)
高音单元	77mm圆锥形(2个)

无线麦克风

电源工作电压	DC3.7V - 4.2V (一节18650锂电池)
工作电流	> 80mA
频率	U段变频: 640 - 689 MHz
通道	MIC A: 640 - 664 MHz (A01 - A48) MIC B: 665 - 689 MHz (B01 - B48)
动态范围	> 105 dB
频率响应	40Hz - 15kHz
拾音器	动圈式 / 单指向性

电源及其他

电源电压	AC110 - 260V 50/60Hz
电源功耗	37.8 W
外形尺寸 (长 x 高 x 宽)	481 x 240 x 233 mm
净重	8.9 Kg

附属品

使用说明书	1
电源线	1
遥控器	1
无线麦克风	(MIC A, MIC B) 2
USB 数据线	1

- 为了改善产品而改变上述规格和外观时，本公司将不予另行通告。

产品规格(BCQ-M65dB)

功能放大器部分

最大输出	88W / 4Ω
频率特性	20Hz - 20kHz
音乐输入灵敏度	710mV
麦克风输入灵敏度	20mV
吉他输入灵敏度	710mV
耳机 / 录音输出端子	2.3V

扬声器部分

低音单元	160mm圆锥形(2个)
高音单元	77mm圆锥形(2个)

无线麦克风

电源工作电压	DC3.7V - 4.2V (一节18650锂电池)
工作电流	> 80mA
频率	U段变频: 640 - 689 MHz
通道	MIC A: 640 - 664 MHz (A01 - A48) MIC B: 665 - 689 MHz (B01 - B48)
动态范围	> 105 dB
频率响应	40Hz - 15kHz
拾音器	动圈式 / 单指向性

电源及其他

电池	8000mAh
电源电压	AC110 - 240V 50/60Hz
电源功耗	37.8 W
外形尺寸 (长 x 高 x 宽)	481 x 240 x 233 mm
净重	9.7 Kg

附属品

使用说明书	1
电源适配器	1
遥控器	1
无线麦克风	(MIC A, MIC B) 2
USB 数据线	1

- 为了改善产品而改变上述规格和外观时，本公司将不予另行通告。

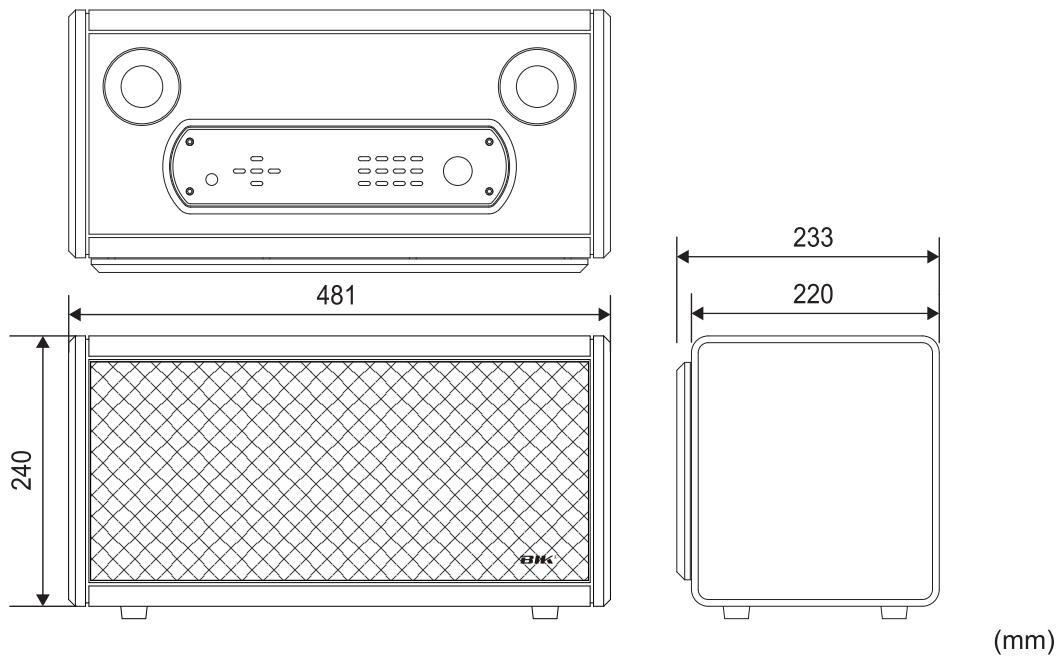

B-Questa®
BIK®

株式会社 ビーアイケー
〒343-0856 埼玉県越谷市谷中町3丁目17-1

BIK CO.,LTD.
3-17-1 YANAKA-CHO. KOSHIGAYA-SHI. SAITAMA-KEN. 343-0856 JAPAN
TEL. +81-48-969-6533 FAX. +81-48-969-6556
URL. <https://www.bik-audio.com> Email. best-sound@bik-coltd.jp